

# MODEL 2400-100 RECIPROCATING SLICER

**UBE**  
UNITED BAKERY EQUIPMENT CO.



# MODEL 2400-100 Reciprocating Slicer



The model 2400-100 uses a durable crankcase and knife frame. The 2400-100 features the efficient continuous flow loaf feed - as a result the 2400-100 has greater speed and a better slice.

## FEATURES:

- Continuous flow loaf feed reduces loaf penetration rate
- Three inch [76.2mm] stroke crankcase
- Stainless tubular frame with aluminum doors and guards
- Simple infeed adjustment for up to 16" [400mm] loaf length
- Double loaf eliminator on outfeed flight conveyor
- Connects to all baggers and wrapper - BISSC approved

## OPTIONS:

- Knife frame from 1/4" to 2" [6.3mm to 50.8mm] slice thickness
- Loaf splitter and turners - heel removers
- Blade oiling system - loaf boosters
- 20" [508mm] loaf length capacity and odd size loaf capacity
- Loaf counter - dual controls and other special requirements
- Flighted infeed loaf timer & feeder

## SPECIFICATIONS:

- Slicing speed-----Up to 55 loaves per minute
- Min./max.loaf size-----.6" x3" x3"/16 x10" x6" (l-w-h)  
[152.4 x76.2 x76.2mm/406.4 x254 x152mm] (l-w-h)
- Slice thickness-----To customer specification
- Blade size-----7/16" pin slot / 430ft./min. [290mm pin slot/131m/ min]
- Electrical-----208/230/380/460 v, 3 ph, 50/60 Hz 3hp [2.5 kva]

## TECHNICAL LAYOUT:

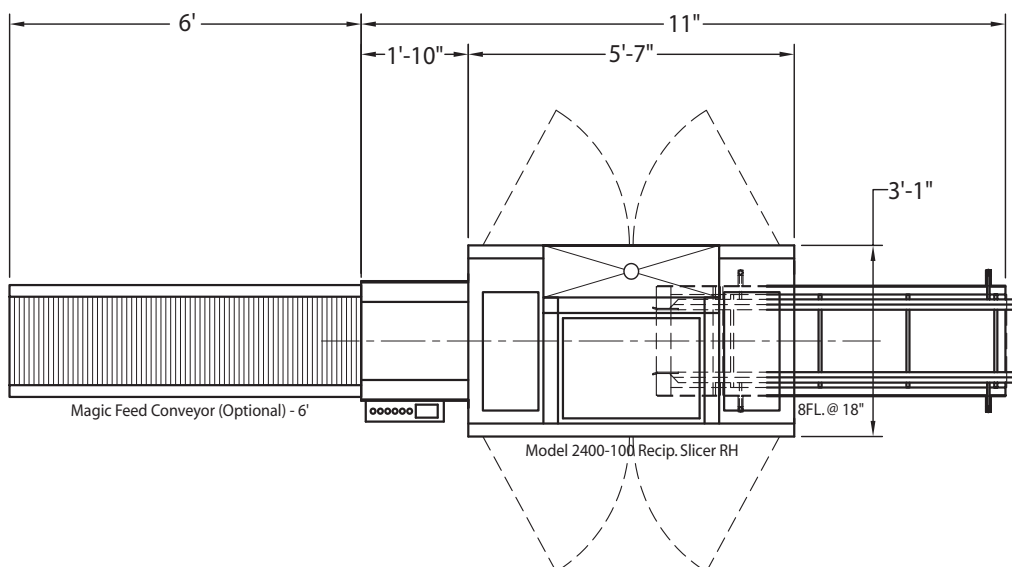

For more information please contact:

United Bakery Equipment Co.

West Coast Sales & Manufacturing  
1921 S. Laurel Park Road  
Rancho Dominguez, CA 90220  
Tel: (310) 635-8121  
Fax: (310) 635-8171  
sales@ubeusa.com

Mid-West Sales & Manufacturing  
15815 W.110th  
Lenexa, KS 66219  
Tel: (913) 541-8700  
Fax: (913) 541-0781  
officeks@ubeusa.com

www.ubeusa.com

(November-2004)